

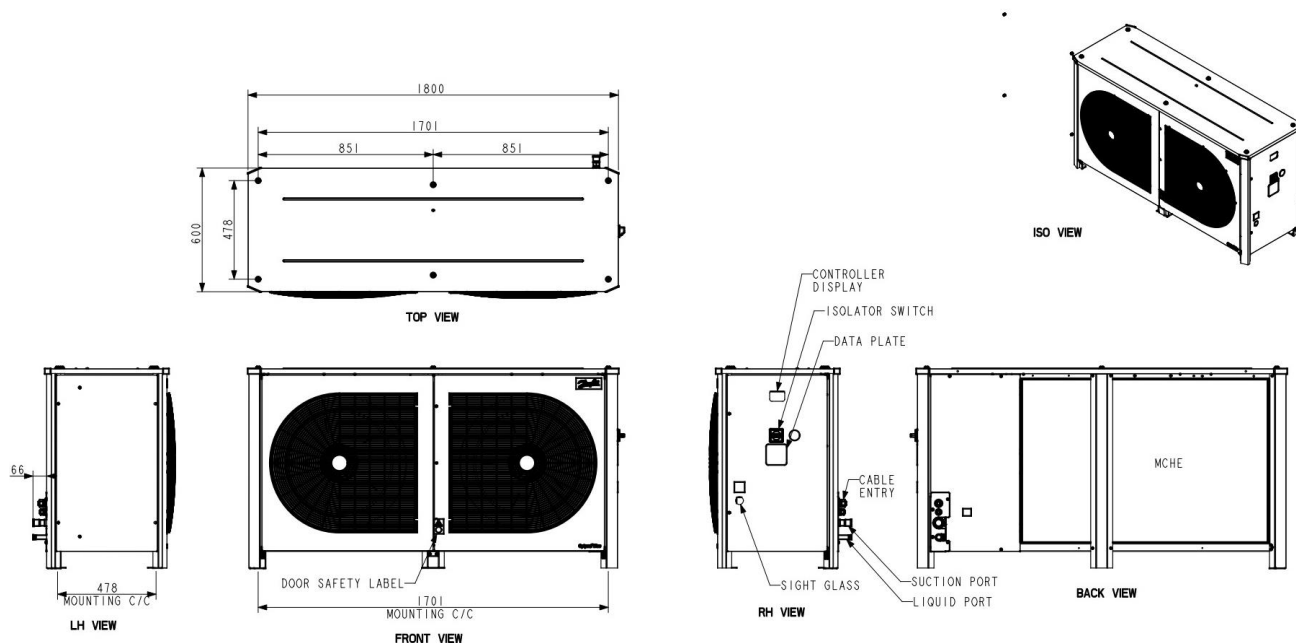

## Danfoss Optyma™ Plus, 114X3486 OP-LPOM168LLP02E

Gross weight	228 Kg	Min fuse rating [A]	32 A
Net weight	166 Kg	Model number	OP-LPOM168LLP02E
Volume	1726.725 Liter	No. of phases (compressor)	3
Air flow @ 50Hz [m³/h]	7500 m³/h	No. of phases (fan)	1
Applications	LBP	Number of fans	2
Capacity control	Fixed speed	Number of receivers	1
Compressor model	LLZ034T4A	Phase	3
Compressor power supply [V]	400/3/50	Product group	Condensing Units
Condenser Coil Internal Volume	1.97 mm³	Product Name Description	Package unit
Condenser type	J7	Receiver approval	PED
Connection type	Solder		RoHS
Description	OP-LPOM168LLP02E		EAC
Electrical code	E	Receiver volume [L]	10 L
Family	Optyma™ Plus	Refrigerants	R404A
Fan blade size [mm]	500 mm		R448A
Fan cowl/grill type	Grill		R449A
Fan current @ 50Hz [A]	0.96 A		R452A
Fan diameter [mm]	500 mm	Segment usage	Low Back Pressure
Fan power consumption @ 50Hz [W]	190 W	Sound power @ 50Hz [db(A)]	79 dBA
Fan power output @ 50Hz [W]	220 W	Sound pressure level 50Hz (@1 m distance) [db(A)]	68 dBA
Fan power supply [V/Ph/Hz]	230/1/50	Sound pressure level 50Hz (@10 m distance) [db(A)]	48 dBA
Fan voltage @ 50Hz (max) [V] [Max]	253 V	Suction connection size [in]	1 1/8 in
Fan voltage @ 50Hz (max) [V] [Min]	207 V	Technology	Scroll
Frequency [Hz]	50 Hz	Total height [mm]	966 mm
High value of nominal voltage at 50Hz [V]	440 V	Type	Optyma™ Plus P02
In scope of WEEE and contain batteries	No	Version	P02
Length [mm]	1835 mm	Voltage 50Hz [V]	360 V
Liquid injection	Yes	Voltage 50Hz [V] [Max]	440 V
Liquid line connection [in]	3/4 in	Width [mm]	650 mm
Low value of nominal voltage at 50Hz [V]	360 V		

## DIMENSIONS



## Performance data R404A/R507 LBP

Model	Code	version	Refrigerant group	electrical code (1)	tamb [°C]	Cooling capacity Q [KW] (2)							EcoDesign (3)		Min Fuse rating gL/μG(A)	Sound press. level 10m dB(A)
						Evaporating Temperature (Mid point) [°C]							COP	SEPR		
						-40° C	-35°C	-30°C	-25°C	-20°C	-15°C	-10°C				
OP-LPOM168LL	114X3486	P02	A1	E	27	5.20	6.48	7.96	9.62	11.47	13.50	-	-	1.68	32	48
					32	3.70	5.88	7.22	8.72	10.37	12.19	-				
					38	4.04	5.09	6.26	7.56	8.99	10.55	-				
					43	3.44	4.38	5.40	6.53	7.77	9.11	-				